



P70, P72, and P170 Series Controls for High Pressure Applications

Description

The P70, P72, and P170 Controls for high pressure applications are designed primarily for high pressure cut-out control, head-pressure control, and condenser fan cycling control on commercial refrigeration and air conditioning applications.

Controls are available in several pressure ranges and are compatible with most common refrigerants. They may also be used on other non-corrosive fluid applications. Ammonia compatible models are also available.

Several different electrical ratings and switch configurations are available. The P72 models provide direct control of 208-240 volt single-phase motors up to 3 horsepower, and 208-220 volt 3-phase motors up to 5 horsepower.

Refer to the *P70, P72, and P170 Series Controls for High Pressure Applications Product/Technical Bulletin (LIT-125454)* for important product application information.

Features

- all-steel case and cover provides long lasting, rugged protection for internal components
- sight-set calibrated pressure adjustment displays a visible pressure scale, fully adjustable through the range without removing the cover (on NEMA 1 enclosure models)

- manual reset lockout option provides trip-free lockout that cannot be overridden or reset until pressure returns to specified level
- variety of available pressure connection styles allows greater flexibility when mounting control and adapting pressure connections to field application requirements

Applications

- **P70C, P70D P170C and P170D models** with single-pole, single-throw (SPST) Open High switch action are the most popular models, and are typically used for high-pressure cutout. The **C models** are automatic reset. The **D models** have a manual reset lockout mechanism. Some **P70C, P70D P170C and P170D models** are UL Listed as refrigeration pressure limiting controls.
- **P70A and P170A models** are available with SPST Open Low switch action, and typically are used for condenser fan cycling control.
- **P70 and P170 models** with single-pole, double-throw (SPDT), or four-wire, two-circuit switch action allow users to install alarm devices or other control circuits.



P70CA-3 High Pressure Cutout Control

- **P72 models** have a double-pole, single-throw (DPST) switch with load-carrying contacts that can provide direct control of 208-240 V single-phase motors up to 3 horsepower, and 208-220 V 3-phase motors up to 5 horsepower. See the DPST Electrical Ratings (P72A, B, C, and D Models) that follow.

NEMA 1 enclosures are standard on most models.

Repair Information

If the P70, P72, and P170 Series Controls for High Pressure Applications fail to operate within their specifications, replace the units. For a replacement control, contact the nearest Johnson Controls® representative.

Selection Chart (Part 1 of 2)

Product Code Number	Switch Action	Range psi (kPa)	Differential psi (kPa)	Pressure Connection	Max. Working Pressure
Condenser Fan Cycling Controls (for Non-Corrosive Refrigerants)					
P70AA-118C	SPST Open Low	100 to 400 (690 to 2,758)	Minimum 35 (241) Maximum 200 (1,379)	36 in. Capillary with 1/4 in. Flare Nut	475 psig (3,275 kPa)
P72AA-27C	DPST Open Low				
P170AA-118C	SPST Open Low				
All Range Controls (for Non-Corrosive Refrigerants)					
P70CA-2C ¹	SPST Open High	50 to 500 (345 to 3,448)	Minimum 60 (414); Maximum 150 (1,034)	1/4 in. External Flare Connector	525 psig (3,620 kPa)
P70CA-3C ¹				36 in. Capillary with 1/4 in. Flare Nut	
P70DA-1C ¹				Manual Reset Lockout	
P70KA-1C	Four-wire, Two-circuit Line-M1 Close High Line-M2 Open High				
P72CA-2C ¹	DPST Open-high		Minimum 60 (414); Maximum 150 (1,034)	1/4 in. External Flare Connector	
P72DA-1C ¹		Manual Reset Lockout			
P170CA-3C ¹	SPST Open High		Minimum 60 (414); Maximum 150 (1,034)	1/4 in. External Flare Connector	
P170DA-1C		Manual Reset Lockout			
P170KA-1C	Four-wire, Two-circuit Line-M1 Close High Line-M2 Open High				

The performance specifications are nominal and conform to acceptable industry standards. For applications at conditions beyond these specifications, consult with Johnson Controls, Inc. shall not be liable for damages resulting from misapplication or misuse of its products. © 2015 Johnson Controls, Inc.



Standard Electromechanical Pressure Controls

P70, P72, and P170 Series Controls for High Pressure Applications (Continued)

Selection Chart (Part 2 of 2)

Product Code Number	Switch Action	Range psi (kPa)	Differential psi (kPa)	Pressure Connection	Max. Working Pressure
Models for High Pressure Non-Corrosive Refrigerants²					
P70AA-2C	SPST Open Low	0 to 150 (0 to 1,034)	Minimum 10 (69); Maximum 70 (483)	36 in. Cap. with 1/4 in. Flare Nut	325 psig (2,241 kPa)
P170AA-2C				1/4 in. External Flare Connector	
P70AA-400C	SPST Open High	100 to 470 (689 to 3,241)	Minimum 35 (241); Maximum 200 (1,379)	36 in. Cap. with 1/4 in. Flare Nut	690 psig (4,757 kPa)
P170AA-400C				1/4 in. External Flare Connector	
P70CA-400C ¹	SPST Open High	200 to 610 (1,379 to 4,206)	Minimum 60 (414); Maximum 150 (1,034)	36 in. Cap. with 1/4 in. Flare Nut	
P170CA-400C ¹				1/4 in. External Flare Connector	
P70DA-400C ¹			Manual Reset Lockout	36 in. Cap. with 1/4 in. Flare Nut	
P170DA-400C ¹					
Ammonia Compatible Models					
P70AA-119C	SPST Open Low	50 to 300 (345 to 2,068)	Minimum 20 (138); Maximum 120 (827)	1/4 in. SS Internal NPT	400 psig (2,758 kPa)
P70CA-5C ¹	SPST Open-High	50 to 500 (345 to 3,448)	Minimum 60 (414); Maximum 150 (1,034)		525 psig (3,620 kPa)
P70DA-2C ¹			Manual Reset Lockout		
P70KA-7C	Four-wire, Two-circuit Line-M1 Close-high Line-M2 Open High				

1. UL Listed as refrigeration pressure limiting controls
2. Compatible with R410A refrigerant.

Note: To order models not listed in the selection chart, please contact Johnson Controls/PENN Refrigeration Application Engineering at 1-800-275-5676.

Technical Specifications

Single Pressure Controls Switch Action, Low Event, High Event, and Models

Switch and Action	Low Event	High Event	Models
SPST Open Low	Cut-Out (Opens Line to M1)	Cut-In (Closes Line to M1)	P70A, P70B, P170A
SPST Open High	Cut-In (Closes Line to M1)	Cut-Out (Opens Line to M1)	P70C, P70D, P170C, P170D
SPDT	Opens 1 to 2 and closes 1 to 3	Closes 1 to 2 and Opens 1 to 3	P70E, P70F
Four-wire, Two-circuits, 1 N.O., 1 N.C. Open Low	Cut-Out (Opens M2 to Line and Closes M1 to Line)	Cut-In (Closes M2 to Line and Opens M1 to Line)	P70G, P70H
Four-wire, Two-circuits, 1 N.O., 1 N.C. Open High	Cut-In (Closes M2 to Line and Opens M1 to Line)	Cut-Out (Opens M2 to Line and Closes M1 to Line)	P70J, P70K, P170K
DPST Open Low	Cut-Out (Opens M1 to Line and M2 to Line)	Cut-In (Closes M1 to Line and M2 to Line)	P72A, P72B
DPST Open High	Cut-In (Closes M1 to Line and M2 to Line)	Cut-Out (Opens M1 to Line and M2 to Line)	P72C, P72D

The performance specifications are nominal and conform to acceptable industry standards. For applications at conditions beyond these specifications, consult the Johnson Controls, Inc. shall not be liable for damages resulting from misapplication or misuse of its products. © 2015 Johnson Controls, Inc.



P70, P72, and P170 Series Controls for High Pressure Applications (Continued)

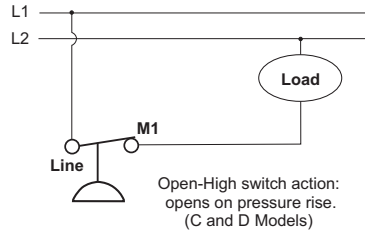
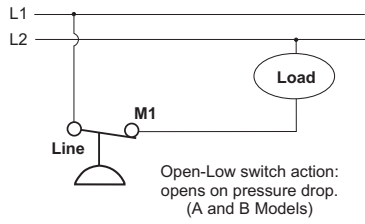

**Typical Wiring for SPST
(P70A, B, C, D, and P170A, C, D, Models)**

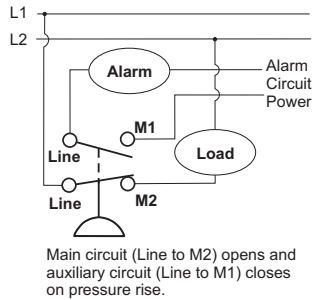

**Typical Wiring for Four-Wire Two-Circuit Switch used for a
High Pressure Cutout Application with an Alarm Circuit
(P70J, K, and P170K Models)**

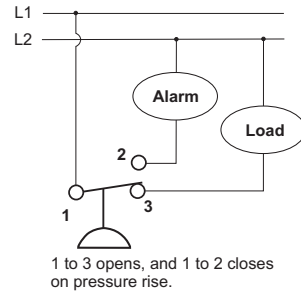

Typical Wiring for SPDT Switch (P70E, F Models)

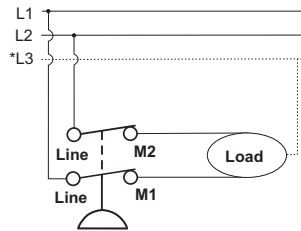

Typical Wiring for DPST Switch (P72C, and D Models)

The performance specifications are nominal and conform to acceptable industry standards. For applications at conditions beyond these specifications, consult the Johnson Controls, Inc. shall not be liable for damages resulting from misapplication or misuse of its products. © 2015 Johnson Controls, Inc.



Standard Electromechanical Pressure Controls

P70, P72, and P170 Series Controls for High Pressure Applications (Continued)

Technical Specifications (Continued)

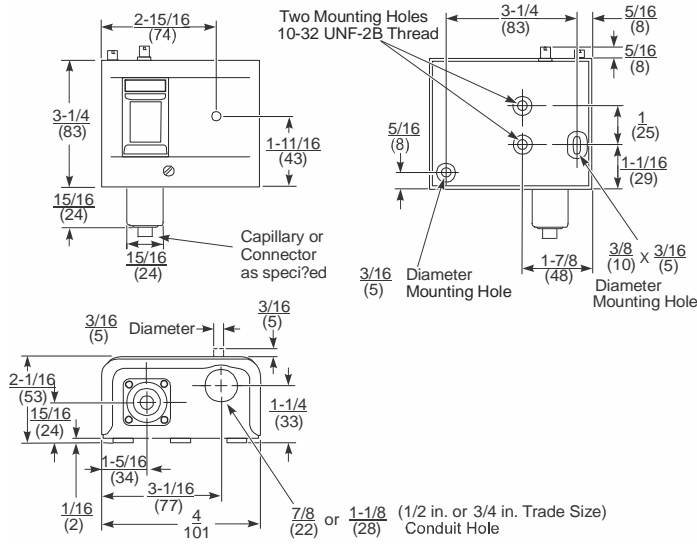

Dimensions for High Pressure Controls with NEMA 1 Enclosure, in. (mm)*

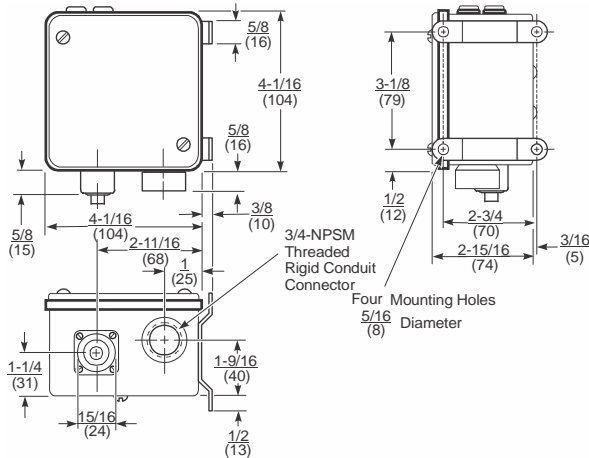

Dimensions for High Pressure Controls with NEMA 3R Enclosure, in. (mm)*

* These dimensions are nominal and are subject to accepted manufacturing tolerances and application variables.

SPST Electrical Ratings (P70A, B, C, and D, and P170A, C, and D Models)

	Single-Phase Ratings			
	Standard			Hermetic Compressor
	120 VAC	208 VAC	240 VAC	208/240 VAC
Motor Horsepower	2	3	3	--
Motor Full-Load A	24	18.7	17	24
Motor Locked-Rotor A	144	112.2	102	144
Non-Inductive A	22	22	22	--
Pilot Duty	125 VA at 120 to 600 VAC; 57.5 VA at 120 to 300 VDC			

SPDT Electrical Ratings 1hp Switch (P70E Models)

	Standard Single-Phase Ratings			
	120 VAC	208 VAC	240 VAC	277 VAC ¹
Motor Full Load A	16.0	9.2	8.0	7.0
Motor Locked Rotor A	96.0	55.2	48.0	42.0
Non-Inductive A	16.0	9.2	8.0	-
Pilot Duty	125 VA at 120 to 600 VAC		125 VA at 24 to 600 VAC	

1. Rating for P70EC models only

SPDT Electrical Ratings 1/4 hp Switch (P70F Models)

	Standard Single-Phase Ratings		
	120 VAC	208 VAC	240 VAC
Motor Full Load A	6.0	3.3	3.0
Motor Locked Rotor A	36.0	19.8	18.0
Non-Inductive A	6.0	6.0	6.0
Pilot Duty	125 VA at 24 to 240 VAC		

Four-wire, Two-circuit Electrical Ratings (P70G, H, J, and K, and P170K Models)

	Standard Single-Phase Ratings							
	Line-M2 (Main Contacts)				Line-M1 (Auxiliary Contacts)			
	120 VAC	208 VAC	240 VAC	277 VAC	120 VAC	208 VAC	240 VAC	277 VAC
Motor Full Load A	16.0	9.2	8.0	--	6.0	3.3	3.0	--
Motor Locked Rotor A	96.0	55.2	48.0	--	36.0	19.8	18.0	--
Non-Inductive A	16.0	9.2	8.0	7.2	6.0	6.0	6.0	6.0
Pilot Duty for both sets of contacts	125 VA at 24 to 600 VAC; 57.5 VA at 120 to 300 VDC							

DPST Electrical Ratings (P72A, B, C, and D Models)

	Standard Ratings					Hermetic Compressor Ratings	
	120 VAC, Single-Phase	208 VAC, Single-Phase	240 VAC, Single-Phase	208 VAC, Three-Phase	220 VAC, Three-Phase	208 VAC, Single-Phase	240 VAC, Single-Phase
Motor Horsepower	2	3	3	5	5	--	--
Motor Full-Load A	24	18.7	17	15.9	15	24	24
Motor Locked-Rotor A	144	112.2	102	95.4	90	144	144
AC Non-Inductive A	24	24	24	24	24	--	--
DC Non-Inductive A	3	0.5	0.5	0.5	0.5	--	--
Pilot Duty	125 VA at 120 to 600 VAC; 57.5 VA at 120 to 300 VDC						

The performance specifications are nominal and conform to acceptable industry standards. For applications at conditions beyond these specifications, consult the Johnson Controls, Inc. shall not be liable for damages resulting from misapplication or misuse of its products. © 2015 Johnson Controls, Inc.